

INSTALLATION INSTRUCTIONS High-Performance Fairing

WARNING

Installation of the anti-rotation bolt is mandatory!

The anti-rotation bolt holds the fairing firmly in place. Failure to install the anti-rotation bolt may result in the fairing rotating while the boat is underway. The effect may be violent movement and loss of steering. This could result in serious injury or death to passengers and/or damage to the boat or other property.

05/30/17

17-276-01 rev. 14

Follow the safety precautions below to reduce the risk of poor product performance, property damage, personal injury, and/or death.

IMPORTANT: Use these instructions along with your transducer installation instructions. These instructions supersede all other instructions where they differ.

WARNING: Always wear safety goggles, a dust mask, and ear protection when installing.

WARNING: The fairing must be installed parallel to the keel to ensure proper boat handling.

WARNING: Do not install a fairing that has been mis-cut. Replace it.

- Cutting the fairing at an angle greater than the maximum allowed will cut into the transducer and/or bolt pocket, thus weakening the fairing.
- Do not allow any gap between the fairing and the hull that is greater than 3mm (1/8"). When the boat is underway, water will enter any gaps and push against the fairing with considerable force, possibly rotating it.

WARNING: A stainless steel transducer and anti-rotation bolt must be isolated from a metal hull to prevent electrolytic corrosion. Use the isolation sleeving supplied.

CAUTION: Do not over-tighten the hull nut and nut on the anti-rotation bolt, crushing the fairing and/or hull.

CAUTION: The transducer and the yellow triangular plug must be flush with the fairing for smooth water flow under the transducer.

CAUTION: Never use products containing strong solvents. Cleaners, fuel, paint, sealants, and other products may contain strong solvents, such as acetone, which attack plastics, greatly reducing their strength.

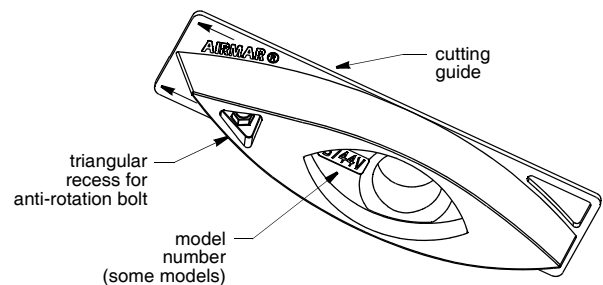

Tools & Materials

Safety goggles
Dust mask
Ear protection
Electric drill
Drill bits and hole saws (see Specifications Table 1)
Pilot hole 3mm or 1/8"
Angle finder
Band saw (sharp blade)
Rasp or power tool
Sandpaper
File (installation in metal hull)
Mild household detergent or weak solvent (such as alcohol)
Marine sealant (suitable for below waterline)
Slip-joint pliers
Mallet
For installation in a cored fiberglass hull, additional tools and materials are needed (see page 4)

Identify Your Transducer Model

The transducer model number is printed on the cable tag.

Specifications Table 1

Transducer Model	Max. Deadrise Angle	Min. Fairing Thickness	Drill Bit/Hole Saw for Transducer Hole	Drill Bit for Anti-rotation Bolt Hole
B45	26°	35mm (1-3/8")	22mm or 7/8"	11mm or 7/16"
B258	26°	60mm (2-3/8")	30mm or 1-3/16"	14mm or 9/16"
B260	20°	74mm (2-7/8")	33mm or 1-5/16"	14mm or 9/16"
B265LH	20°	74mm (2-7/8")	33mm or 1-5/16"	14mm or 9/16"
B265LM	20°	74mm (2-7/8")	33mm or 1-5/16"	14mm or 9/16"
B271W	26°	60mm (2-3/8")	30mm or 1-3/16"	14mm or 9/16"
B275LHW	20°	74mm (2-7/8")	33mm or 1-5/16"	14mm or 9/16"
B285HW	26°	60mm (2-3/8")	30mm or 1-3/16"	14mm or 9/16"
B285M	26°	60mm (2-3/8")	30mm or 1-3/16"	14mm or 9/16"
B744V	24°	32mm (1-1/4")	51mm or 2"	11mm or 7/16"
B744VL	24°	32mm (1-1/4")	51mm or 2"	11mm or 7/16"
B765LH	24°	32mm (1-1/4")	51mm or 2"	11mm or 7/16"
B765LM	24°	32mm (1-1/4")	51mm or 2"	11mm or 7/16"
B785M	24°	32mm (1-1/4")	51mm or 2"	11mm or 7/16"
SS258	26°	60mm (2-3/8")	30mm or 1-3/16"	14mm or 9/16"
SS258 in metal hull	26°	60mm (2-3/8")	35mm or 1-3/8"	15mm or 9/16"
SS260	20°	74mm (2-7/8")	33mm or 1-5/16"	14mm or 9/16"
SS260 in metal hull	20°	74mm (2-7/8")	35mm or 1-3/8"	15mm or 9/16"
SS270W	20°	74mm (2-7/8")	33mm or 1-5/16"	14mm or 9/16"
SS270W in metal hull	20°	74mm (2-7/8")	35mm or 1-3/8"	15mm or 9/16"
SS505	25°	32mm (1-1/4")	22mm or 7/8"	11mm or 7/16"
SS505 in metal hull	25°	32mm (1-1/4")	25mm or 1"	13mm or 1/2"

Installation

Hole Drilling: Transducer

Cored Fiberglass Hull—Follow separate instructions on page 4.

1. Drill a 3mm or 1/8" pilot hole perpendicular to the waterline from inside the hull (see Figure 1). If there is a rib, strut, or other hull irregularity near the selected mounting location, drill from the outside.
2. Using the appropriate size drill bit or hole saw, cut a hole from outside the hull (see Specifications Table 1). *Be sure to hold the drill plumb, so the hole will be perpendicular to the water surface.*

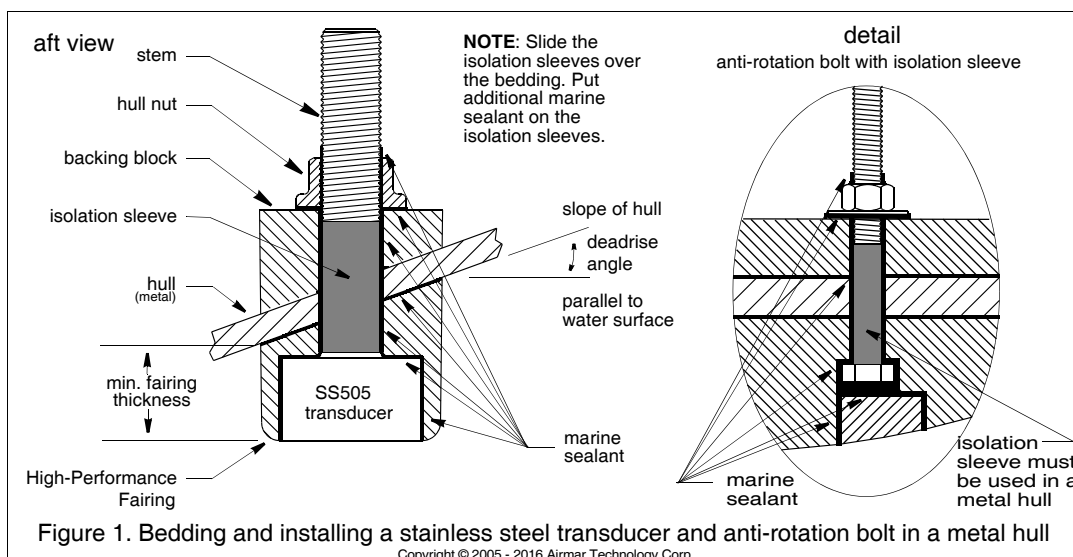

Figure 1. Bedding and installing a stainless steel transducer and anti-rotation bolt in a metal hull

Copyright © 2005 - 2016 Airmar Technology Corp.

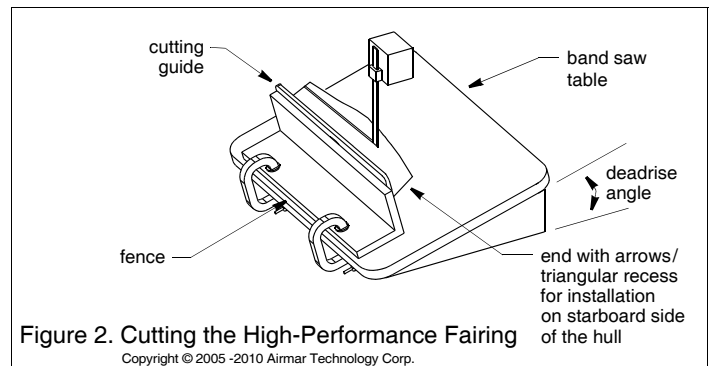

Figure 2. Cutting the High-Performance Fairing

Copyright © 2005 - 2010 Airmar Technology Corp.

Cutting the High-Performance Fairing

CAUTION: The end of the fairing with the arrows/triangular recess always points forward toward the bow when installed. Be sure to orient the fairing on the band saw, so the angle cut matches the intended side of the hull and not the mirror image.

1. Measure the deadrise angle of the hull at the selected mounting location using an angle finder (see Figure 1). *Check to be sure the angle does not exceed the maximum allowed (see Specifications Table 1).*
2. Tilt the band saw table to the measured angle and secure the cutting fence (see Figure 2).
3. Place the fairing on the table, so the cutting guide rests against the fence. The end with the triangular recess will be pointing *toward* you for installation on the starboard side of the boat or pointing *away* from you for installation on the port side.
4. Adjust the cutting fence, so the fairing will be cut in about two equal parts. There is a minimum thickness for the fairing at its thinnest dimension (see Figure 1 and Specifications Table 1).
5. Recheck steps 1 through 4. Then cut the fairing.
6. When the boat is underway, especially at high speeds, water will enter any gaps and push against the fairing with considerable force, possibly rotating it. Shape the fairing to the hull as precisely as possible with a rasp or power tool. *If there is a gap of more than 3mm (1/8"), replace the fairing.*
7. Check to be sure the transducer is flush with the fairing. If it is recessed more than 0.5mm (1/64") inside the fairing, you may shim the transducer or carefully file/sand the fairing.
8. Use the remaining section of the fairing with the cutting guide for the backing block.

Hole Drilling: Anti-rotation Bolt

Cored Fiberglass Hull—Follow separate instructions on page 4.

To locate and drill the hole for the anti-rotation bolt, use the fairing as a guide. This will ensure that the hole is perpendicular to the waterline and not drilled at the angle of the hull.

1. Dry fit the transducer in the fairing. Thread the cable through the large hole in the fairing and through the mounting hole in the hull. Seat the transducer firmly within the recess in the fairing (see Figure 3).
2. Slide the transducer with the fairing in place into the mounting hole. **Hold the fairing parallel to the keel, being sure the triangular**

recess in the fairing is pointing forward toward the bow. Using the bolt hole in the fairing as your guide, drill a 3mm (1/8") pilot hole through the hull for the anti-rotation bolt.

- Using the appropriate size drill bit or hole saw and holding the fairing in place, drill a hole for the anti-rotation bolt (see Specifications Table 1).
- Remove the assembly and cable from the mounting hole.
- Sand and clean the area around both holes, inside and outside, to ensure that the sealant will adhere properly to the hull. If there is any petroleum residue inside the hull, remove it with either mild household detergent or a weak solvent such as alcohol before sanding.

Metal hull—Remove all burrs with a file and sandpaper.

Bedding the Transducer

CAUTION: Be sure the surfaces to be bedded are clean and dry.

- Remove the transducer from the fairing.
- Apply a 2mm (1/16") thick layer of marine sealant to the surface of the transducer that will contact the fairing and up the stem. *The sealant must extend 6mm (1/4") higher than the combined thickness of the fairing, hull, backing block, and hull nut (see Figure 3).* This will ensure there is marine sealant in the threads to seal the hull and hold the hull nut securely in place.

Stainless steel transducer/stem in a metal hull—Slide the isolation sleeve over the bedded transducer stem as far down as possible (see Figure 1). Apply a 2mm (1/16") thick layer of the marine sealant to the outside of the sleeving.

- Apply a 2mm (1/16") thick layer of marine sealant to the following surfaces:

- Fairing that will contact the hull
- Backing block that will contact the hull interior
- Hull nut that will contact the backing block

- Thread the transducer cable through the fairing and seat the transducer firmly within the recess.

Installing the Transducer

- From outside the hull, thread the transducer cable through the mounting hole. Push the stem of the transducer (with the fairing in place) into the mounting hole using a twisting motion to squeeze out excess sealant (see Figure 3).

NOTE: The transducer must be **FLUSH** with the fairing. If it is recessed more than 0.5mm (1/64") inside the fairing, you may shim the transducer or carefully file/sand the fairing.

Stainless steel transducer/stem in a metal hull—Be sure the isolation sleeve is between the transducer stem and the hull (see Figure 1). However, the top of the isolation sleeve must be below the top of the backing block to prevent the sleeving from interfering with tightening the hull nut.

- From inside the hull, slide the backing block onto the transducer cable and stem, seating the backing block firmly against the hull. Slide the hull nut along the cable. *Screw the hull nut in place, but do not tighten it at this time.*

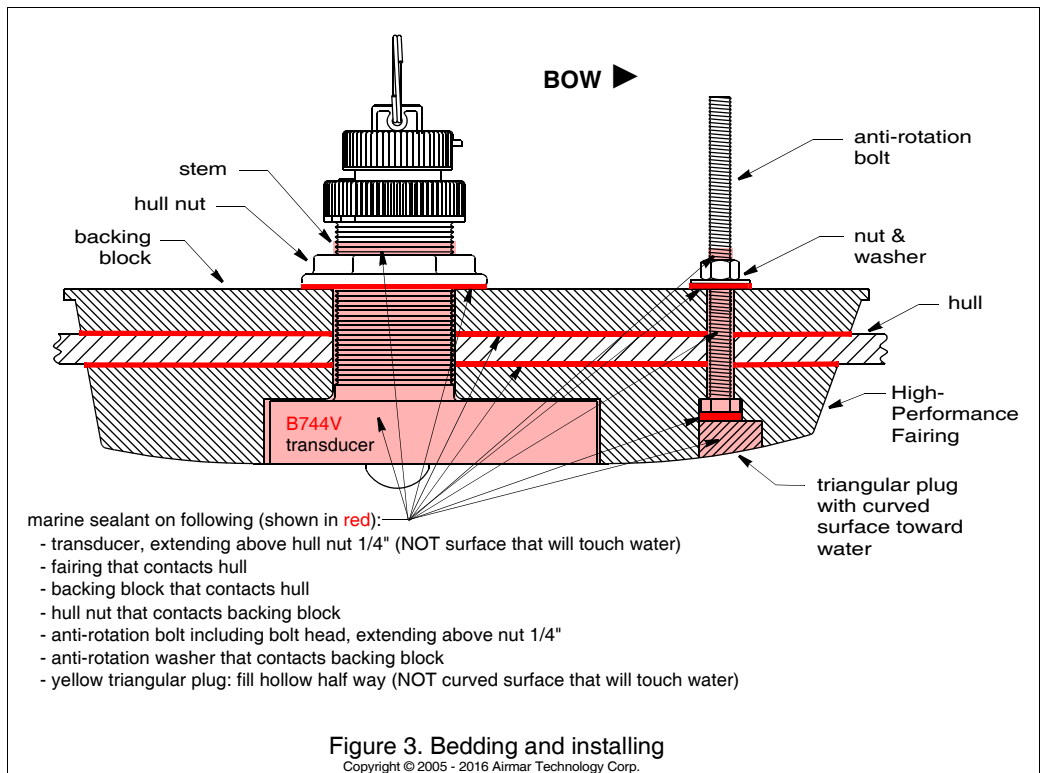

Bedding & Installing the Anti-rotation Bolt

CAUTION: Be sure the surfaces to be bedded are clean and dry.

- Apply a 2mm (1/16") thick layer of marine sealant to the anti-rotation bolt *including the flange* (see Figure 3). The sealant must be 6mm (1/4") higher than the combined thickness of the fairing, hull, backing block, washer, and nut. This will ensure that there is marine sealant on the threads to seal the hull and hold the nut securely in place.

Stainless steel bolt in a metal hull—Slide the isolation sleeve over the bedded bolt as far down as possible (see Figure 1 detail). Apply a 2mm (1/16") thick layer of the marine sealant to the outside of the sleeving.

- Apply a 2mm (1/16") thick layer of marine sealant to the side of the washer that will contact the backing block.
- Push the anti-rotation bolt through the fairing and the hull.
- From inside the hull, screw the washer (sealant side down) and the nut onto the anti-rotation bolt.

Stainless steel bolt in a metal hull—Be sure the isolation sleeve is between the bolt and the hull (see Figure 1 detail). However, the top of the isolation sleeve must be below the top of the backing block to prevent the sleeving from interfering with tightening the hull nut.

- Use slip-joint pliers to tighten the hull nut. Then tighten the nut on the anti-rotation bolt. *Do not over-tighten, crushing the fairing or hull.*

Cored fiberglass hull—Do not over tighten, crushing the hull.
Wood hull—Allow for the wood to swell before tightening the nuts.

- Use marine sealant to half fill the hollow in the yellow triangular plug. Apply a 2mm (1/16") thick layer of marine sealant to the three sides of the plug that form the triangle. The sealant will hold the plug firmly within the fairing and fill any gap between the anti-rotation bolt and the plug.
- The yellow triangular plug fits one way only.* The curved surface will touch the water. Push the yellow plug into the recess in the fairing until it is **FLUSH** with the outside of the fairing. This will squeeze out excess sealant. If necessary, tap it into place with a mallet.

NOTE: If the triangular plug is slightly recessed within the fairing, use sealant to fill the gap. The plug must be **FLUSH** with the fairing for good performance.

- When the boat is underway, especially at high speeds, water will enter any gaps and push against the fairing with considerable force, possibly rotating it. Fill any gaps between the fairing and the hull with marine sealant. **If there is any gap greater than 3mm (1/8"), replace the fairing.** Remove the excess sealant on the outside of the fairing and hull to ensure smooth water flow under the transducer.
- Proceed with the installation instructions that came with your transducer, beginning with "Cable Routing & Connecting."

Installation in a Cored Fiberglass Hull

The core (wood or foam) must be cut and sealed carefully. The core must be protected from water seepage, and the hull must be reinforced to prevent it from crushing under the hull nut, allowing the transducer to become loose.

Additional Tools & Materials

Drill bits and hole saws (see Specifications Table 2)

Cylinder

Wax

Tape

Casting epoxy

Specifications Table 2

Model	Drill Bit/Hole Saw for Transducer (outer skin)	Min. Size Drill Bit/Hole Saw for Transducer (inner cored hull)	Drill Bit for Anti-rotation Bolt (outer skin)	Min. Size Drill Bit for Anti-rotation Bolt (inner cored hull)
B45 SS505	22mm or 7/8"	38mm or 1-1/2"	11mm or 7/16"	25mm or 1"
B258 B271W B285HW B285M SS258	30mm or 1-3/16"	50mm or 2"	14mm or 9/16"	30mm or 1-1/4"
B260 B265LH B265LM B275LHW SS260 SS270W	33mm or 1-5/16"	50mm or 2"	14mm or 9/16"	30mm or 1-1/4"
B744V B744VL B765LH B765LM B785M	51mm or 2"	65mm or 2-5/8"	11mm or 7/16"	25mm or 1"

Preparing the Hull

CAUTION: Completely seal the hull to prevent water seepage into the core.

- Drill a 3mm or 1/8" pilot hole perpendicular to the waterline from inside the hull (see Figure 4). If there is a rib, strut, or other hull irregularity near the selected mounting location, drill from the outside. (If the hole is drilled in the wrong location, drill a second hole in a better location. Apply masking tape to the outside of the hull over the incorrect hole and fill it with epoxy.)
- Using the appropriate size drill bit or hole saw, cut a hole from outside the hull through the *outer* skin only (see Specifications

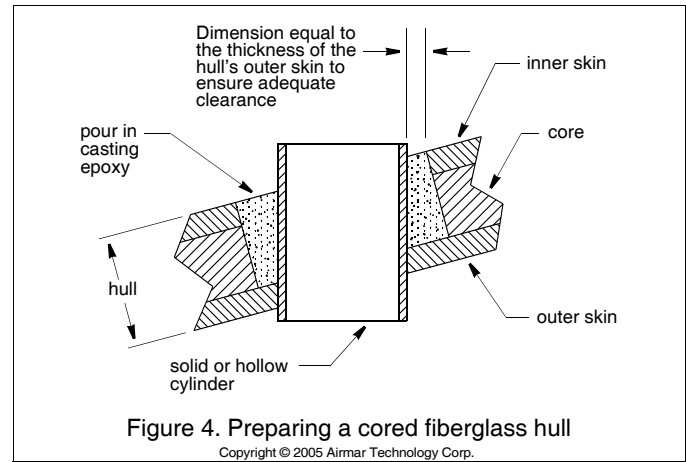

Table 2). Be sure to hold the drill plumb, so the hole will be perpendicular to the water surface.

- The optimal interior hole diameter is affected by the hull's thickness and deadrise angle. It must be large enough in diameter to allow the core to be completely sealed.

Using the appropriate size drill bit or hole saw cut through the *inner* skin and most of the core from inside the hull keeping the drill perpendicular to the hull (see Specifications Table 2). The core material can be very soft. Apply only light pressure to the hole saw after cutting through the *inner* skin to avoid accidentally cutting the *outer* skin.

- Remove the plug of core material, so the *inside* of the outer skin and the inner core of the hull is fully exposed. Sand and clean the inner skin, core, and the outer skin around the hole.
- Coat a hollow or solid cylinder of the correct diameter with wax and tape it in place. Fill the gap between the cylinder and hull with casting epoxy. After the epoxy has set, remove the cylinder.
- Sand and clean the area around the hole, inside and outside, to ensure that the sealant will adhere properly to the hull. If there is any petroleum residue inside the hull, remove it with either mild household detergent or a weak solvent, such as alcohol, before sanding.
- Follow the same procedure to prepare the hull for the anti-rotation bolt ("Installation in a Cored Fiberglass Hull", steps 2 through 6).
- Proceed with the installation beginning with "Cutting the Fairing" on page 2.

Replacement Parts

Obtain parts from your instrument manufacturer or marine dealer.

Gemeco

Tel: 803-693-0777

(USA)

Fax: 803-693-0477

email: sales@gemeco.com

Airmar EMEA

Tel: +33.(0)2.23.52.06.48

(Europe, Middle East, Africa)

Fax: +33.(0)2.23.52.06.49

email: sales@airmar-emea.com



35 Meadowbrook Drive, Milford, New Hampshire 03055-4613, USA

• www.airmar.com

Copyright © 2004 - 2017 Airmar Technology Corporation. All rights reserved.